

ES Valve

[www.fishvalve.nt-rt.ru](http://www.fishvalve.nt-rt.ru)

Product Bulletin

# Fisher® ES and EAS Sliding-Stem Control Valves

Fisher ES and EAS general-purpose control valves (figures 1 and 2) are used for throttling or on-off control of a wide variety of liquids and gases. Both valve designs have single ports, unbalanced valve plugs, and cage guiding.

In both designs, metal-to-metal seating is standard for all general applications over a wide range of pressure drops and temperatures. Metal-to-PTFE seating is optional for more stringent shutoff requirements.

The Fisher ES product line is available for a wide range of applications, including sulfide and chloride stress-cracking environments common to the oil and gas production industries. To discuss available constructions, contact your Emerson Process Management sales office and include the applicable codes and standards required for these environments.

## The easy-e™ Valve Family

ES and EAS valves are part of the versatile easy-e family of Fisher industrial control valves. easy-e valves share the following characteristics.

- Multiple trim material choices
- Trim temperature capability with standard metal seats to 427°C (800°F)
- Flexible graphite gaskets
- Interchangeable, restricted-capacity trims and full-flow trims to match variable process flow demands
- Trim part interchangeability that permits reconfiguring the valve to a different design variation



W2174-1  
**FISHER ES CONTROL VALVE  
WITH 657 ACTUATOR**

- Different cage/plug styles provide particular flow characteristics for highly-specialized applications. The standard cage comes in three different flow characteristics:
  - quick-opening
  - linear
  - equal percentage
- Whisper Trim™ I cages (figure 1) that attenuate aerodynamic noise in gaseous service are available for all sizes except the NPS 8 ES valve.
- Optional constructions provide material compatibility with NACE MR0175-2002.
- 316 stainless steel packing box parts are standard (including packing flange, studs, and nuts).



## Features

- **Compliance with the Clean Air Act**— Optional ENVIRO-SEAL™ packing systems (figure 3) provide an improved stem seal to help prevent the loss of process fluid. The ENVIRO-SEAL packing systems feature PTFE, Graphite ULF, or Duplex packing with live-loading for reduced packing maintenance.
- **Valve Plug Stability**— Rugged cage guiding provides increased valve plug stability, which reduces vibration and mechanical noise.
- **Economy**— Streamlined flow passages provide higher efficiency and greater capacities per initial investment.
- **Cost-Effective Operation**— Increased wear resistance of the standard hardened stainless steel trim means long-lasting service. Also, trim inventory costs are cut because dimensional standardization permits use of most standard easy-e trim parts.
- **Easy Maintenance**— The valve can stay in the pipeline during removal of trim parts for inspection or maintenance.
- **Long-Lasting Shutoff Capability with PTFE Seating**— Controlled compression of optional seat construction protects PTFE disk between metal disk seat and disk retainer (figure 1). The flowstream contacts only the edge of the disk during normal operation.
- **Compliance with European Standards**— Valves are available with dimensions specified by EN/DIN standards. See figure 7 and the note in figure 8.
- **Sour Service Capability**— Unless otherwise noted, references are to NACE MR0175-2002. Optional materials are available to meet NACE MR0103 and NACE MR0175 / ISO15156. Material requirements under these standards vary by edition and year of issue; the specific standard must be specified.

## Table of Contents

Features .....	2	Maximum Flow Coefficients .....	11
Specifications .....	3	Materials and Temperature Limits for	
ENVIRO-SEAL Packing System		All Other Parts .....	12
Specifications .....	4	Metal Trim Part Materials for	
ENVIRO-SEAL and HIGH-SEAL		Compatibility with NACE MR0175-2002	
Packing Systems .....	5	(Sour Service) Specifications, Environ-	
Class VI Shutoff Capabilities .....	5	mental Restrictions Apply, Refer to	
Tables		Standard .....	13
Class VI Tables .....	5	Bolting Materials and Temperature Limits	
Available Constructions .....	6	for Bolting Compliance with	
Typical Combinations of		NACE MR0175-2002 .....	15
Metal Trim Parts .....	7	Port Diameters, Valve Plug Travel, and	
Valve Body/Trim Temperature		Stem and Yoke Boss Diameters .....	15
Capabilities .....	9	Dimensions .....	17
Bonnet Selection Guidelines .....	9		

## ES Valve

## Specifications

## Available Configurations

**ES:** Single-port, globe-style control valve with cage guiding, unbalanced valve plug, and push-down-to-close valve plug action (figure 1)  
**EAS:** Angle version of ES control valve, used to facilitate piping or in applications where a self-draining valve is desired (figure 2)

## Valve Sizes

See table 3

End Connection Styles<sup>(1)(2)</sup>

## Cast Iron Valves

*Flanged:* ES, NPS 1 through 8, including NPS 1-1/2 and 2-1/2 (except NPS 1-1/4), ■ CL125 flat-face or ■ CL250 raised-face flanges per ASME B16.1

## Steel and Stainless Steel Valves

*Flanged:* ■ CL150, 300, or 600 raised-face (RF) or ring-type joint (RTJ) flanges per ASME B16.5, ■ Raised-face (RF) flanges per EN1092-1/B  
*Screwed or Socket Welding:* NPS 1/2 through 2, consistent with ASME B16.11

*Buttwelding:* NPS 1 through 8 (except NPS 1-1/4). Schedules 40 or 80 consistent with ASME B16.25

Maximum Inlet Pressures and Temperatures<sup>(1)(2)</sup>

As listed below, unless limited by maximum pressure drop or material temperature capabilities

## Cast Iron Valves

*Flanged:* Consistent with CL125B or 250B per ASME B16.1

## Steel and Stainless Steel Valves

*Flanged:* Consistent with CL150, 300, and 600<sup>(3)</sup> per ASME B16.34

*Screwed or Welding:* Consistent with flanged CL600<sup>(3)</sup> per ASME B16.34

Maximum Pressure Drop<sup>(2)</sup>

Same as maximum inlet pressure for specific construction defined above, except where further limited as shown in figures 5 and 6

**Valves for NACE MR0175-2002:** See figure 5

## Shutoff Classifications per ANSI/FCI 70-2 and IEC 60534-4

**Metal Seating:** Class IV is standard. Class V is optional  
**PTFE Composition Seating:** Class VI

## Construction Materials

**Body, Bonnet, and Bonnet Spacer or Bottom Flange, if used:** ■ WCC carbon steel, ■ CF8M stainless steel, ■ LCC carbon steel, ■ WC9 chrome moly steel; ■ Cast iron body with steel bonnet construction  
**Other material constructions upon request**  
**Valve Plug, Cage, and Metal Seating Parts:** See table 4  
**All Other Parts:** See table 9

Material Temperature Capabilities<sup>(2)</sup>

**Body/Trim Combinations:** See tables 4 and 6  
**Those For NACE Specification:** See tables 10 and 11  
**All Other Parts:** See table 9

## Flow Characteristics

**Standard Cages:** ■ Quick-opening, ■ linear, or ■ equal percentage  
**Whisper Trim:** Linear

## Flow Directions

## ES

*Standard Cage:* Normally up  
*Whisper Trim Cages:* Always up

## EAS

*Standard Cage:* Without liner, flow up or down; with liner, normally down  
*Whisper Trim Cages:* Always up

## Flow Coefficients and Noise Level Prediction

See table 8 and Catalog 12

## Port Diameters and Maximum Valve Plug Travels

See table 12

## Yoke Boss and Stem Diameters

See table 12

## Typical Bonnet Styles

■ Plain or ■ extension. See figures 7 and 8 for standard dimensions. See table 7 for selection guidelines

■ ENVIRO-SEAL bellows seal bonnet. See figure 4 for view of ENVIRO-SEAL bellows seal bonnet. Also, see Bulletin 59.1:070, ENVIRO-SEAL Bellows Seal Bonnets, for further information

- continued -

Specifications (continued)

**Packing Arrangements**

**Standard Material:** Single PTFE V-ring  
**ENVIRO-SEAL Packing:** See figure 3  
*ENVIRO-SEAL Packing Systems in vacuum service:*  
 Standard ENVIRO-SEAL packing systems can be used in vacuum service with packing rings in standard orientation. Do not reverse the ENVIRO-SEAL PTFE packing rings.

Also see Bulletin 59.1:061, ENVIRO-SEAL Packing Systems for Sliding-Stem Valves, for more information.

**Approximate Weights**

**NPS 1/2 and 3/4:** 9 kg (20 lb)  
**NPS 1 and 1-1/4:** 14 kg (30 lb)

**NPS 1-1/2:** 20 kg (45 lb)  
**NPS 2:** 39 kg (85 lb)  
**NPS 2-1/2:** 45 kg (100 lb)  
**NPS 3:** 57 kg (125 lb)  
**NPS 4:** 77 kg (170 lb)  
**NPS 6:** 159 kg (350 lb)  
**NPS 8:** 408 kg (900 lb)

**Additional Options**

■ Lubricator, ■ lubricator/isolating valve, ■ drilled and tapped connection in extension bonnet for leakoff service, ■ body drain plug, ■ style 3 fabricated extension bonnet made on order to a specific length for cryogenic service, and ■ Whisper Trim III cage for NPS 6 ES valve body

1. EN (or other) ratings and end connections can usually be supplied; consult your Emerson Process Management sales office.  
 2. The pressure/temperature limits in this bulletin, and any applicable standard limitations should not be exceeded.  
 3. Certain bonnet bolting material selections may require a CL600 easy-e valve assembly to be derated. Contact your Emerson Process Management sales office for more information

**ENVIRO-SEAL Packing System Specifications**

**Applicable Stem Diameters**

■ 9.5 mm (3/8 inches), ■ 12.7 (1/2), ■ 19.1 (3/4), ■ 25.4 (1), and ■ 31.8 (1-1/4) diameter valve stems

**Maximum Pressure/Temperature Limits<sup>(1)</sup>**

**To Meet the EPA Fugitive Emission Standard of 100 PPM<sup>(2)</sup>**  
*For ENVIRO-SEAL PTFE and ENVIRO-SEAL Duplex packing systems:* full CL300 up to 232°C (450°F)  
*For ENVIRO-SEAL Graphite packing:* 104 bar (1500 psig) at 316°C (600°F)

**Construction Materials**

**PTFE Packing Systems:**  
*Packing Ring and Lower Wiper:* PTFE V-ring<sup>(3)</sup>  
*Male and Female Adaptor Rings:* Carbon-filled PTFE V-ring

**Graphite ULF Packing Systems:** Graphite rings  
**Duplex Packing Systems:**  
*Male and Female Adaptor Rings:* Carbon-filled PTFE V-ring  
*Guide Bushings:* Carbon graphite  
*Packing Rings:* Graphite composite  
*Packing Washer:* PTFE  
**Anti-Extrusion Washer:** Filled PTFE (not required for graphite or duplex packing)  
**Lantern Ring:** S31600 (316 stainless steel) (not required for graphite packing)  
**Packing Box Flange:** S31600  
**Spring:** ■ 17-7PH stainless steel or ■ N06600  
**Packing Follower:** S31600 lined with carbon-filled PTFE  
**Packing Box Studs:** Strain-hardened 316 stainless steel  
**Packing Box Nuts:** 316 stainless steel

1. Refer to the valve specifications in this bulletin for pressure/temperature limits of valve parts. Do not exceed the pressure/temperature rating of the valve. Do not exceed any applicable code or standard limitation.  
 2. The Environmental Protection Agency (EPA) has set a limit of 100 parts per million (ppm) for fugitive emissions from a valve in selected VOC (Volatile Organic Compound) services.  
 3. In vacuum service, it is not necessary to reverse the ENVIRO-SEAL PTFE packing rings.

ES Valve

**Table 1. Class VI Shutoff Availability**

Valve	Port Size, Inches	Seat	Minimum Seat Load
ES	≤ 7	Metal	300 lbs/lineal inch

**Table 2. Class VI Trim Materials**

VALVE	CAGE/SEAT RING RETAINER	VALVE PLUG	SEAT RING	TRIM TEMPERATURE LIMIT	
				°C	°F
ES	S31600 (316 SST) / ENC	S31600/CoCr-A (alloy 6) seat	S31600	Not a limiting factor	Not a limiting factor

## ENVIRO-SEAL, HIGH-SEAL Packing Systems

ENVIRO-SEAL and HIGH-SEAL packing systems offer excellent sealing capabilities. They easily install in your existing valves or can be purchased with new valves. These systems may help prevent the loss of process fluid. The long operational life and reliability of these systems also helps to reduce your maintenance costs and downtime.

For applications requiring compliance with environmental protection regulations, the unique Fisher ENVIRO-SEAL packing system (figure 3) and a unique ENVIRO-SEAL bellows seal system (figure 4) are offered. The emission control packing system helps to keep emission concentrations below the EPA 100 ppm requirement.

For an excellent stem seal in applications that are not environmentally-sensitive, the Fisher HIGH-SEAL

Graphite ULF packing system is offered. The HIGH-SEAL packing system provides excellent sealing at pressure/temperature ratings beyond ENVIRO-SEAL limits.

ENVIRO-SEAL packing systems, available with PTFE, Graphite ULF, or Duplex packing, and the HIGH-SEAL packing systems, Graphite ULF and graphite composite, feature live-loading and unique packing-ring arrangements for long-term, consistent sealing performance.

## Class VI Shutoff Capabilities

ES valves with metal seat constructions can provide ANSI/FCI Class VI shutoff capabilities. See tables 1 and 2.

Table 3. Available Valve Body Constructions

VALVE	VALVE SIZE, NPS	BODY MATERIAL AND END CONNECTION STYLE <sup>(1)</sup>							
		Screwed	Carbon Steel, Alloy Steel, or Stainless Steel Valve Body			Butt-welding	Socket Weld	Cast Iron Valve Body	
			RF or RTJ Flanged					CL125 FF Flanged	CL250 RF Flanged
			CL150	CL300	CL600				
ES	1/2 or 3/4	X	---	---	---	---	X	---	---
	1, 1-1/2, or 2	X	X	X	X	X	X	X	X
	1-1/4	X	---	---	---	---	---	---	---
	2-1/2, 3, 4, 6, or 8	---	X	X	X	X	---	X	X
EAS	1 or 2	---	X	X	X	X	---	---	---
	3, 4, or 6	---	X	X	X	X	---	---	---

X = Available Construction.  
 1. End connection style abbreviations: FF - Flat Faced, RF - Raised Face, RTJ - Ring Type Joint.

Figure 1. Fisher ES Sectional

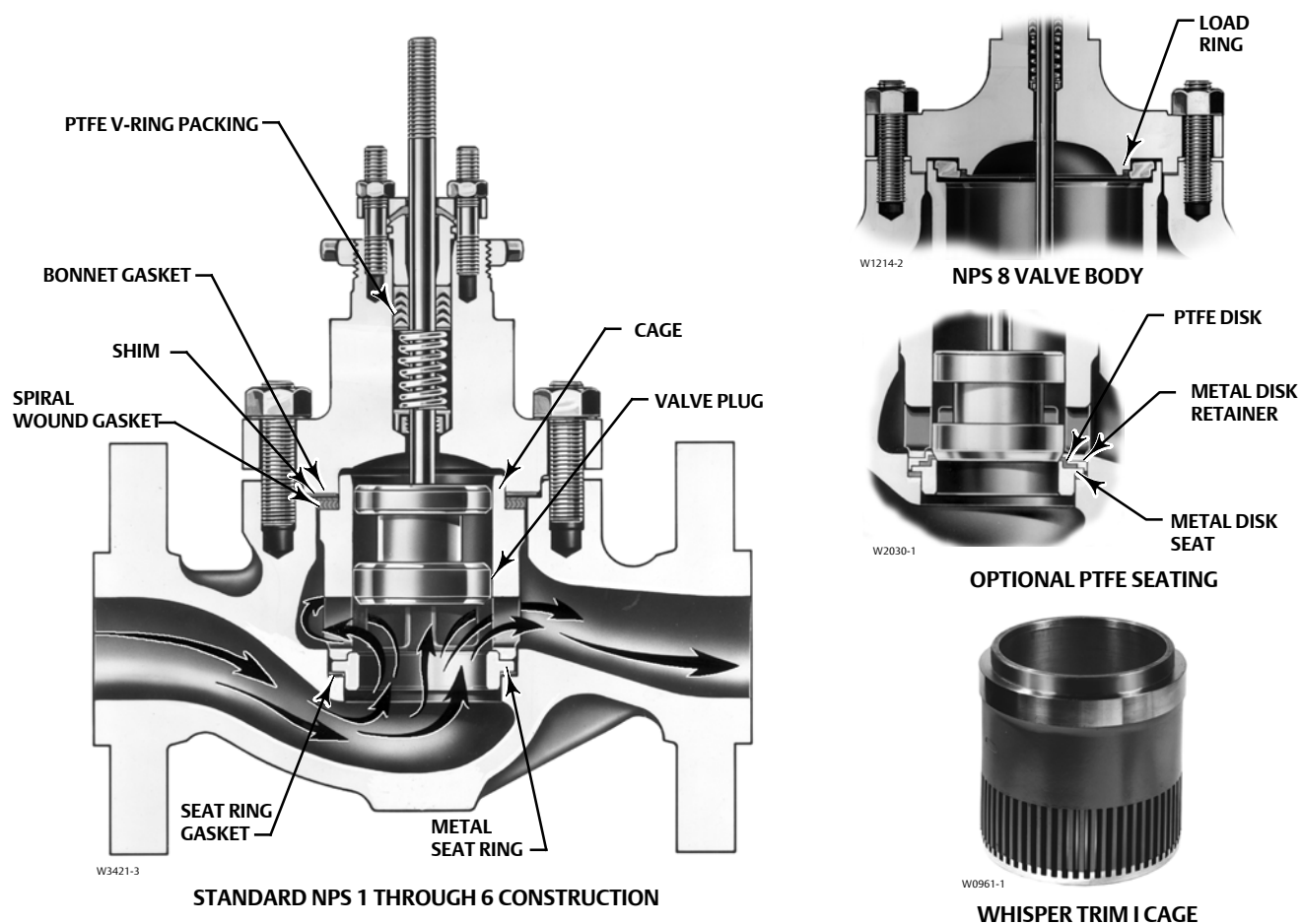

**Table 4. Typical Combinations of Metal Trim Parts<sup>(1)</sup> for all Valves Except Those for NACE Specification and Whisper Trim III Cages**

Trim Designation	Valve Plug	Cage	Seat Ring for Standard Metal-Seat Construction	Optional Liner (Metal-Seat EAS Valve Body Only)	Disk Seat and Retainer for Optional PTFE-Seat Construction
1 (standard for metal-seat ES and EAS in all valve body materials except CF8M)	S41600 HT	CB7Cu-1 HT	S41600 HT or CA15 HT <sup>(1)</sup> (410 stainless steel)	S41600 HT	---
3	S31600 with seat and guide hard faced with CoCr-A hardfacing alloy	R30006 (alloy 6)	R30006 (alloy 6)	---	---
4 <sup>(2)</sup>	S31600	CB7Cu-1 HT	S31600	S31600	S31600
27	S31600 with seat and guide hard faced with CoCr-A hardfacing alloy	CF8M with electroless nickel coating (ENC)	R30006 (alloy 6)	---	---
28 <sup>(3)</sup>	S31600 with seat hard faced with CoCr-A hardfacing alloy				
29 <sup>(3)</sup> (standard for CF8M valve bodies in all designs regardless of seat construction)	S31600	CF8M with ENC	S31600	S31600	S31600
37	S31600 with seat and guide hard faced with CoCr-A hardfacing alloy	CB7Cu-1 HT	R30006 (alloy 6)	---	---
57 (standard for PTFE-seat constructions in all designs and valve body materials except CF8M)	S41600 alloy HT	CB7Cu-1 HT	---	---	S31600

1. CA15 is used for NPS 6 and 8 full-size and restricted-trim valves.  
 2. Not for use with Whisper Trim I.  
 3. Not for use with Whisper Trim I with 136.5 mm (5.375 inch) and larger ports.

**Table 5. Metal Trim Part Combinations for Valves with Whisper Trim III Cages<sup>(1)</sup>**

Trim Designation	Valve Plug	Cage	Cage Retainer	Baffle (for Level D3 Cage Only)	Disk Seat and Retainer for PTFE-Seat Construction	Seat Ring for Metal-Seat Construction
301 (standard for all valve materials except CF8M [316 SST])	S17400 (17-4PH SST) heat treated	S41600 (416 SST) heat treated	WCC/A105 heat-treated (NACE <sup>(3)</sup> with ENC)	Steel	---	S41600 (416 SST) heat treated
304	S31600 with seat and guide hard-faced with CoCr-A (Alloy 6)	S41600 heat treated	WCC/A105 heat-treated (NACE with ENC)	Steel	---	S31600 with seat hard-faced with CoCr-A
312 (for level D NACE)	S31600 with seat and guide hard-faced with CoCr-A	S31600 with ENC	S31600 with ENC	S31600	---	S31600 with seat hard-faced with CoCr-A
313 (NACE compatible) <sup>(2)</sup>	S31600 with seat and guide hard-faced with CoCr-A	S31600 with ENC	WCC/A105 heat-treated (NACE with ENC)	Steel	---	S31600 with seat hard-faced with CoCr-A

1. For NPS 6 valves only.  
 2. Level D3 cage cannot be certified to NACE. Use 316/ENC cage retainer instead.  
 3. Unless otherwise noted, all NACE references are to NACE MR0175-2002.

Figure 2. Fisher EAS Sectional

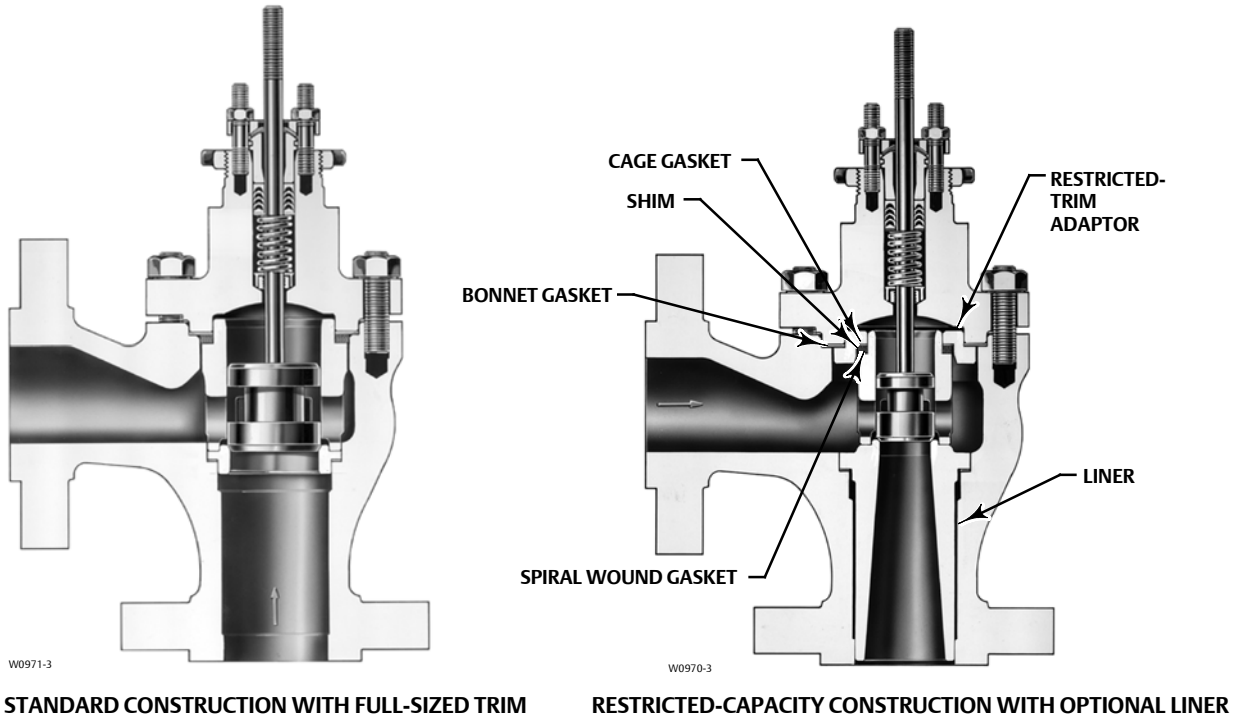



ES Valve

Table 6. Valve Body/Trim Temperature Capabilities for Metal Trim Parts Only

BODY/BONNET MATERIAL (ALSO FOR BOTTOM FLANGE IF USED)	TRIM DESIGNATION	VALVE SIZE AND DESIGN	MATERIAL TEMPERATURE CAPABILITY			
			°C		°F	
			Min	Max	Min	Max
Cast iron body w/ steel bonnet	1, 3, 27, 29, 37, or 57	All	-29	232	-20	450
WCC steel	1, 37, or 57	All	-29	427	-20	800
	29	All	-29	316	-20	600
	54	All	-29	260	-20	500
CF8M (316 SST)	27	All	-198 <sup>(1)</sup>	343	-325 <sup>(1)</sup>	650
	28	All	-198 <sup>(1)</sup>	149	-325 <sup>(1)</sup>	300
	29	All	-198 <sup>(1)</sup>	316	-325 <sup>(1)</sup>	600
LCC steel	1	All	-29	343	-20	650
	4	All	-46	210	-50	410
	29	All	-46	316	-50	600
	37	All	-46	343	-50	650
WC9 chrome moly steel	1, 37, or 57	All	-29	427	-20	800
	3	All	-29	427	-20	800
	3H	All	427	566	800	1050
	27	Through NPS 3 all designs; NPS 8 ES	-29	343	-20	650
		NPS 4 or 6 ES and EAS	-29	343	-20	650
	29	All	-29	316	-20	600

1. May be used down to -254°C (-425°F) if manufacturing process includes Charpy impact test.

Table 7. Bonnet Selection Guidelines

BONNET STYLE	PACKING MATERIAL	IN-BODY PROCESS TEMPERATURE LIMITS <sup>(1)</sup>	
		°C	°F
Plain: ■ Standard for all valves through NPS 6 with 2-13/16 yoke boss diameter ■ Standard for NPS 6 and 8 valves in cast iron and WCC steel bonnet material with 3-9/16 yoke boss diameter	PTFE V-ring	-18 to 232	0 to 450
	PTFE/Composition	-18 to 232	0 to 450
	Graphite ribbon/filament	-18 to maximum shown in table 9	0 to maximum shown in table 9
Style 1 Cast Extension: ■ Standard for NPS 8 valves in S31600 bonnet material with 3-9/16 yoke boss diameter	PTFE V-ring	-46 to 427	-50 to 800
	PTFE/Composition		
	Graphite ribbon/filament	-46 to maximum shown in table 9	-50 to maximum shown in table 9
Style 2 Cast Extension: ■ Optional for NPS 2 through 4 valves with 2-13/16 inch yoke boss diameter ■ Optional for NPS 6 and 8 valves with 3-9/16 yoke boss diameter. Not available for NPS 8 valve in S31600 bonnet material	PTFE V-ring	-101 to 427	-150 to 800
	PTFE/Composition		
	Graphite ribbon/filament	-101 to maximum shown in table 9	-150 to maximum shown in table 9
ENVIRO-SEAL bellows seal bonnet	PTFE	For exceptional stem sealing capabilities. See Bulletin 59.1:070, ENVIRO-SEAL Bellows Seal Bonnets, for pressure/temperature ratings.	For exceptional stem sealing capabilities. See Bulletin 59.1:070, ENVIRO-SEAL Bellows Seal Bonnets, for pressure/temperature ratings.
	Graphite ULF		

1. These in-body process temperatures assume an outside, ambient temperature of 21°C (70°F) and no insulation on the bonnet. When using any packing at low process temperatures, a cast extension bonnet may have to be used to prevent packing damage which could result from the formation of valve stem frost. Material selection for trim and other components will also be limiting factors.

Figure 3. ENVIRO-SEAL and HIGH-SEAL Packing Systems

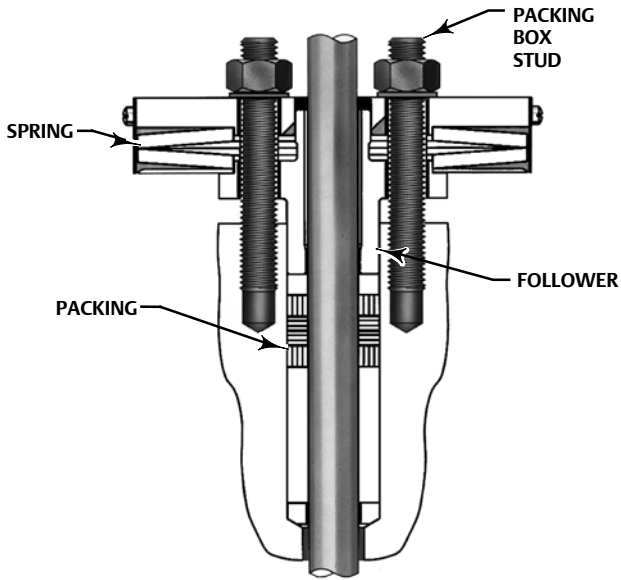

W8533-1

TYPICAL HIGH-SEAL PACKING SYSTEM WITH GRAPHITE ULF PACKING

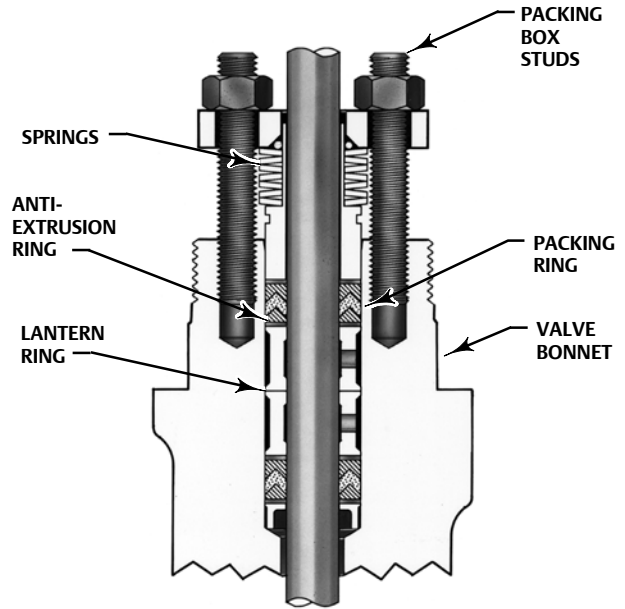

W5803-3

TYPICAL ENVIRO-SEAL PACKING SYSTEM WITH PTFE PACKING

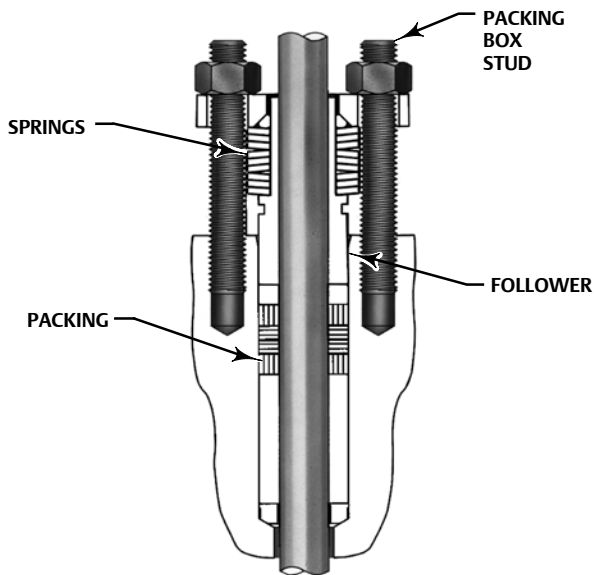

W8532-1

TYPICAL ENVIRO-SEAL PACKING SYSTEM WITH GRAPHITE ULF PACKING

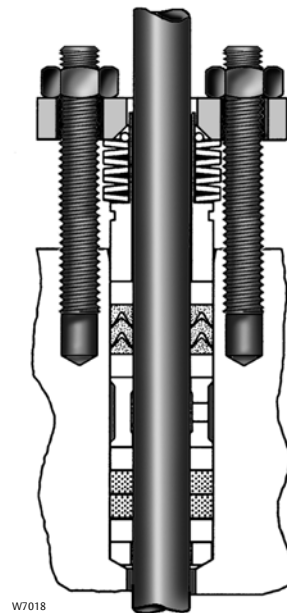

W7018

TYPICAL ENVIRO-SEAL PACKING SYSTEM WITH DUPLEX PACKING

Table 8. Maximum Flow Coefficients for Full-Sized Trim with Equal Percentage Cage and Normal Flow Direction<sup>(1)</sup>

Valve	Valve Size, NPS	C <sub>v</sub> at Max Valve Plug Travel
ES	1/2	6.53 <sup>(2)</sup>
	3/4	14.2 <sup>(2)</sup>
	1, 1-1/4	17.4
	1-1/2	33.4
	2	56.2
	2-1/2	82.7
	3	121
	4	203
EAS (flow down)	6	357
	8	808
	1	19.0
	2	47.2
	3	148
	4	156
	6	328

1. Except where indicated. Flow coefficients for linear and quick-opening cages normally are somewhat greater.  
 2. Quick-opening cage.

Figure 4. ENVIRO-SEAL Bellows Seal Bonnet

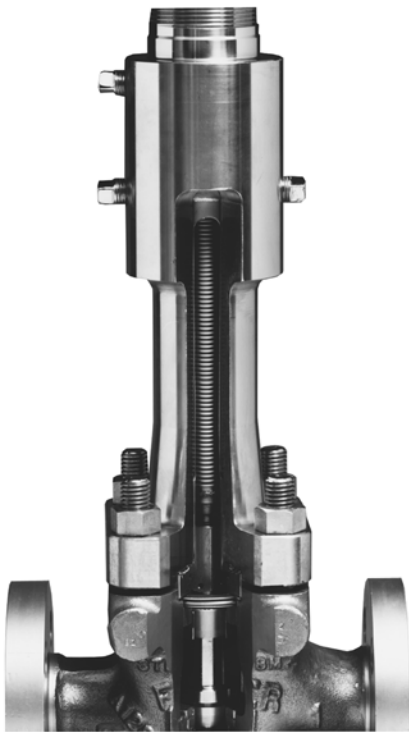

W5852

Table 9. Materials and Temperature Limits for All Other Parts

PART			MATERIAL	MATERIAL TEMPERATURE CAPABILITIES			
				°C		°F	
				Minimum	Maximum	Minimum	Maximum
Body-to-bonnet bolting. See table 11 for NACE bolting materials and temperatures	Cast iron body	Cap screws	Steel SAE Grade 5	-29	232	-20	450
	WCC or WC9 body	Studs	Steel SA-193-B7	-29	427 <sup>(1)</sup>	-20	800 <sup>(1)</sup>
		Nuts	Steel SA-194-2H				
	CF8M body	Studs	Steel SA-193-B7 (std)	-48	427 <sup>(1)</sup>	-55	800 <sup>(1)</sup>
		Nuts	Steel SA-194-2H (std)				
		Studs	304 stainless steel SA-320-B8	-198	38	-325	100
		Nuts	304 stainless steel SA-194-8				
		Studs	316 stainless steel SA-193-B8M (strain-hardened)	-198 <sup>(2)</sup>	427 <sup>(1)</sup>	-325 <sup>(2)</sup>	800 <sup>(1)</sup>
		Nuts	316 stainless steel SA-194-8M				
	Studs	316 stainless steel SA-194-B8M (annealed)	-198 <sup>(2)</sup>	These materials not limiting factors	-325 <sup>(2)</sup>	These materials not limiting factors	
	Nuts	316 stainless steel SA-194-8M					
	LCC body	Studs	Steel SA-193-B7	-46	343 <sup>(1)</sup>	-50	650 <sup>(1)</sup>
Nuts		Steel SA-194-2H					
WC9 body	Studs	Steel SA-193-B16	-29	566 <sup>(1)</sup>	-20	1050 <sup>(1)</sup>	
	Nuts	Steel SA-194-7					
Optional disk			PTFE	-73	204	-100	400
Valve plug stem			316 stainless steel	-198 <sup>(2)</sup>	593	-325 <sup>(2)</sup>	1100
Pin (ES or EAS valve only)			316 stainless steel				
Load ring	(NPS 8 ES valve only)		17-4PH stainless steel	-101	316	-150	600
			N06600	-254	593	-425	1100
			N05500 Nickel Alloy	-240	260	-400	500
Restricted trim adaptors			Cast iron	-73	232	-100	450
			WCC steel	-29	427	-20	800
			316 stainless steel	-198 <sup>(2)</sup>	593	-325 <sup>(2)</sup>	1100
Seat ring, bonnet, and cage gaskets			Flexible Graphite (standard)	-198	593 <sup>(3)</sup>	-325	1100 <sup>(3)</sup>
			PTFE-coated N04400 Nickel Alloy	-73	149	-100	300
Spiral wound gaskets			N06600 Nickel Alloy 600/graphite (Flexible Graphite) standard	-198	593 <sup>(3)</sup>	-325	1100 <sup>(3)</sup>
			N04400 Nickel Alloy/composition	-73	232	-100	450
Shim			316 stainless steel	These materials not limiting factors			
			N04400 Nickel Alloy	These materials not limiting factors			
Packing	(temperatures shown are material temperature capabilities)	See table 7 for proper bonnet selection	PTFE V-ring	-40	232	-40	450
			PTFE/composition	-73	232	-100	450
			Graphite ribbon/filament	-198	538 <sup>(4)</sup>	-325	1000 <sup>(4)</sup>
			Graphite ribbon for high-temperature oxidizing service	371	649	700	1200
Packing flange studs, and nuts when used with standard bonnet			316 stainless steel	-198 <sup>(2)</sup>	593	-325 <sup>(2)</sup>	1100
Packing follower and packing spring (single PTFE V-ring packing) or lantern ring (other packing arrangements)			316 stainless steel	-198 <sup>(2)</sup>	593	-325 <sup>(2)</sup>	1100
Packing box ring			316 stainless steel	-198 <sup>(2)</sup>	593	-325 <sup>(2)</sup>	1100
Extension bonnet bushing	Trims 1 & 4		416 stainless steel	-29	427	-20	800
	Other trims		316 stainless steel	-198 <sup>(2)</sup>	593	-325 <sup>(2)</sup>	1100

1. Lubricated nuts are standard.  
 2. May be used down to -254°C (-425°F) if manufacturing process includes Charpy impact test.  
 3. Except 427°C (800°F) on oxidizing service.  
 4. Except 371°C (700°F) on oxidizing service.

**Table 10. Metal Trim Part Materials for Compatibility with NACE MR0175-2002 (Sour Service) Specifications, Environmental Restrictions Apply, Refer to Standard**

Trim Designation	Valve Plug	Cage	Seat Ring for Standard Metal Seat Construction	Optional Liner for Metal Seat (EAS only)	Disk Seat and Retainer for Optional PTFE-Seat Construction	Valve Stem, Packing Follower, Lantern Ring, Packing Box Ring, and Pin	Load Ring <sup>(1)</sup>
85 <sup>(3)</sup>	S31600	S31600 with ENC	S31600	S31600	---	Valve stem is S20910 All other parts are S31600	N05500
85C <sup>(2, 3)</sup>	S31600	S31600 with ENC	---	---	S31600		
86 <sup>(3)</sup>	S31600 with seat hard faced with CoCr-A hard facing alloy	S31600 with ENC	R30006 (alloy 6)	---	---		
87	S31600 with seat and guide hard faced with CoCr-A hard facing alloy	S31600 with ENC	R30006 (alloy 6)	---	---		
87C <sup>(2)</sup>	S31600 with seat and guide hard faced with CoCr-A hard facing alloy	S31600 with ENC	---	---	S31600		

1. NPS 8 valve only.  
 2. 85C and 87C are trims for PTFE-seat construction.  
 3. Not for use with Whisper Trim I with 136.5 mm (5.375 inch) and larger ports.

Figure 5. Typical Trim Used for NACE MR0175-2002, (Sour Service)

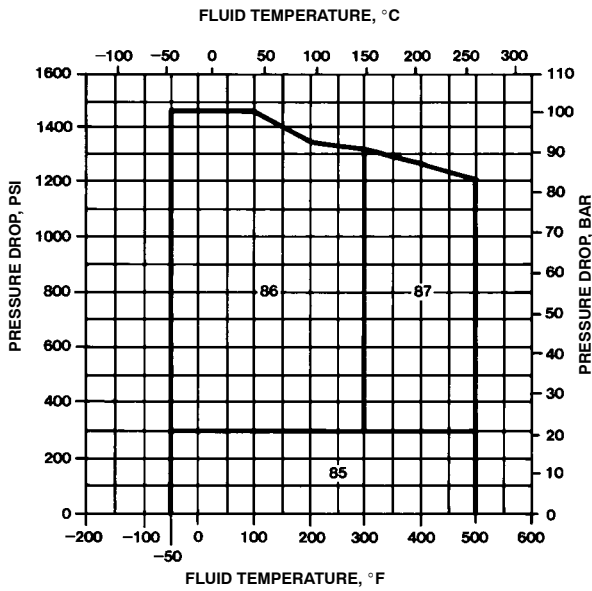

FOR STANDARD METAL SEATING WITH CL600 WCC OR LCC BODY

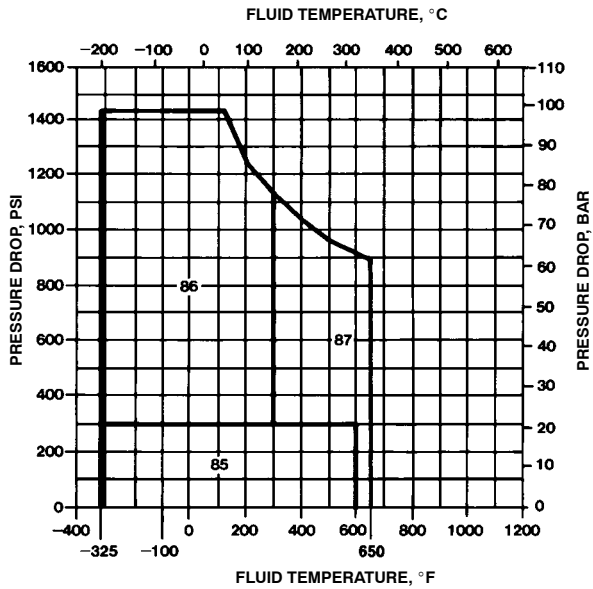

FOR STANDARD METAL SEATING WITH CL600 316 STAINLESS STEEL (CF8M) BODY

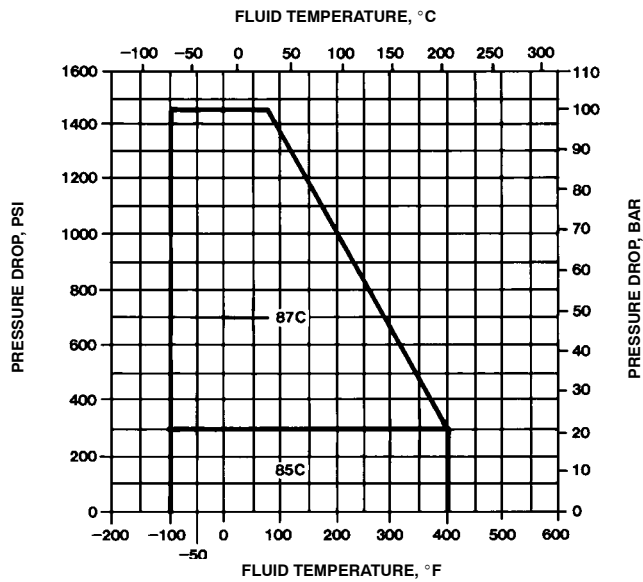

FOR OPTIONAL PTFE SEATING WITH ALL BODY MATERIALS

C0575-3

Note:

Do not exceed the maximum pressure and temperature for the pressure rating of the valve body material used, even though the trims shown may have higher capabilities.

ES Valve

Table 11. Bolting Materials and Temperature Limits for Bolting Compliance with NACE MR0175-2002, NACE MR0175/ISO 15156, and NACE MR0103. Environmental restrictions may apply.

VALVE BODY MATERIAL		BOLTING MATERIAL		TEMPERATURE CAPABILITIES					
				°C		°F			
				Min	Max	Min	Max		
<b>Non-exposed bolting (Standard)</b>									
WCC	Studs	Steel SA-193-B7		-7	232	20	450		
	Nuts	Steel SA-194-2H							
	Studs	Steel SA-193-B7		232	427	450	800		
	Nuts	Steel SA-194-2H							
CF8M (316 SST)	Studs	Steel SA-193-B7 or B8M strain hardened		-48	232	-55	450		
	Nuts	Steel SA-194-2H or 8M							
	Studs	Steel SA-193-B8M strain hardened or B7		232	427	450	800		
	Nuts	Steel SA-194-8M lubricated or 2H							
<b>Exposed bolting (Optional)</b> Requires Derating of Valve <sup>(2)</sup> When These Body-to-Bonnet Bolting Materials are Used									
WCC and CF8M	Studs	Steel SA-193-B7M		-46 <sup>(1)</sup>	232	-50 <sup>(1)</sup>	450		
	Nuts	Steel SA-194-2HM							
	Studs	Steel SA-193-B7M		232	427	450	800		
	Nuts	Steel SA-194-2HM							

1. Minimum temperature is -29°C (-20°F) with WCC valve body material.  
 2. Derating is not required for CL300 valves. Derating may be required for valves rated at CL600. Contact your Emerson Process Management sales office for assistance in determining the derating of valves when these body-to-bonnet bolting materials are used.

Table 12. Port Diameters, Valve Plug Travel, and Stem and Yoke Boss Diameters

VALVE SIZE, NPS				PORT DIAMETER		MAX VALVE PLUG TRAVEL		STEM AND YOKE BOSS DIAMETERS							
ES		EAS						Standard				Optional			
Full-Sized Trim	Restricted-Capacity Trim	Full-Sized Trim	Restricted-Capacity Trim					Stem		Yoke Boss		Stem		Yoke Boss	
				mm	Inch	mm	Inch	mm	Inch	mm	Inch	mm	Inch	mm	Inch
1 or 1-1/4	1-1/2	1	2	33.3	1.3125	19	0.75	9.5	3/8	54	2-1/8	12.7	1/2	71	2-13/16
---	2	---	---	33.3	1.3125	19	0.75	12.7	1/2	71	2-13/16	---	---	---	---
1-1/2	---	2	---	47.6	1.875	19	0.75	9.5	3/8	54	2-1/8	12.7	1/2	71	2-13/16
---	2-1/2	---	3	47.6	1.875	19	0.75	12.7	1/2	71	2-13/16	---	---	---	---
2	3	---	4	58.7	2.3125	29	1.125	12.7	1/2	71	2-13/16	19.1	3/4	90	3-9/16
2-1/2	4	3	6	73.0	2.875	38	1.5	12.7	1/2	71	2-13/16	19.1	3/4	90	3-9/16
3	---	4	---	87.3	3.4375	38	1.5	12.7	1/2	71	2-13/16	19.1	3/4	90	3-9/16
4	---	6	---	111.1	4.375	51	2	12.7	1/2	71	2-13/16	19.1	3/4	90	3-9/16
												25.4	1	127	5
6	---	---	---	177.8	7	51	2					25.4	1	127	5
8	---	---	---	203.2	8	51	2	19.1	3/4	90	3-9/16	or 31.8	or 1-1/4	127	5
						76	3								

Figure 6. Typical Trim Use for All Valve Bodies Except Those for NACE Specifications

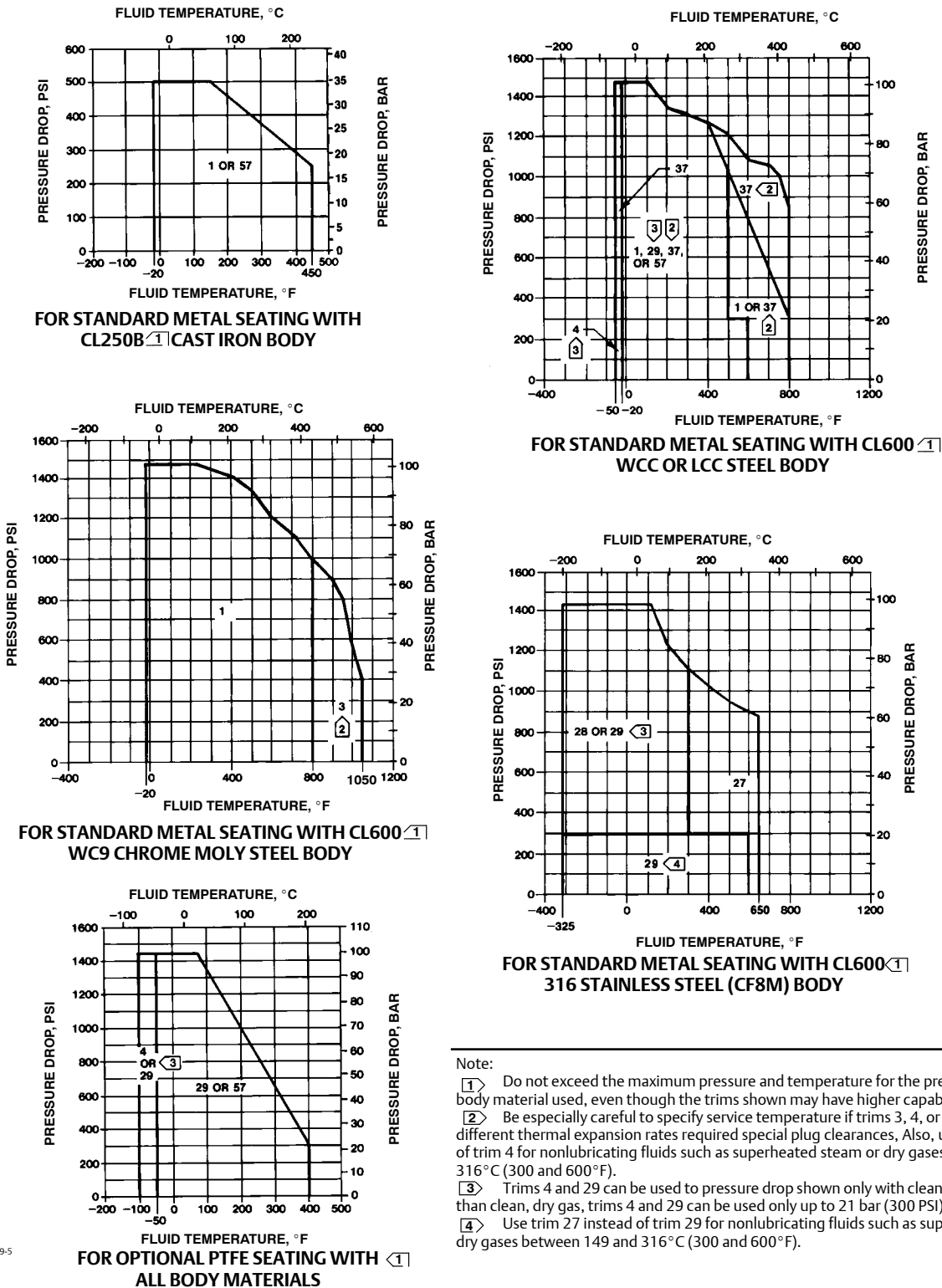

Note:

- (1) Do not exceed the maximum pressure and temperature for the pressure rating of the body material used, even though the trims shown may have higher capabilities.
- (2) Be especially careful to specify service temperature if trims 3, 4, or 37 are selected, as different thermal expansion rates required special plug clearances. Also, use trim 37 instead of trim 4 for nonlubricating fluids such as superheated steam or dry gases between 149 and 316°C (300 and 600°F).
- (3) Trims 4 and 29 can be used to pressure drop shown only with clean, dry gas. For other than clean, dry gas, trims 4 and 29 can be used only up to 21 bar (300 PSI).
- (4) Use trim 27 instead of trim 29 for nonlubricating fluids such as superheated steam or dry gases between 149 and 316°C (300 and 600°F).

C0459-5



ES Valve

Table 13. Fisher ES Dimensions

VALVE SIZE, NPS	A									G(MAX)
	Scrd or SW	125 FF or 150 RF	150 RTJ	250 RF or 300 RF	300 RTJ	BW or 600 RF	600 RTJ	PN 16-40 <sup>(1)</sup>	PN 63-100 <sup>(1)</sup>	ES
mm										
1/2, 3/4	165	---	---	---	---	---	---	---	---	54
1	210	184	197	197	210	210	210	160	230	56
1-1/4	229	---	---	---	---	---	---	---	---	56
1-1/2	251	222	235	235	248	251	251	200	260	71
2	286	254	267	267	282	286	289	230	300	78
2-1/2	---	276	292	292	308	311	314	290	340	90
3	---	298	311	317	333	337	340	310	380	97
4	---	353	365	368	384	394	397	350	430	129
6	---	451	464	473	489	508	511	480	550	140
8	---	543	556	568	584	610	613	600	650	191
Inches										
1/2, 3/4	6.50	---	---	---	---	---	---	See mm above	See mm above	2.12
1	8.25	7.25	7.75	7.75	8.25	8.25	8.25			2.38
1-1/4	9.00	---	---	---	---	---	---			2.38
1-1/2	9.88	8.75	9.25	9.25	9.75	9.88	9.88			2.81
2	11.25	10.00	10.50	10.50	11.12	11.25	11.38			3.06
2-1/2	---	10.88	11.38	11.50	12.12	12.25	12.38			3.56
3	---	11.75	12.25	12.50	13.12	13.25	13.38	3.81		
4	---	13.88	14.38	14.50	15.12	15.50	15.62	5.06		
6	---	17.75	18.25	18.62	19.25	20.00	20.12	5.5		
8	---	21.38	21.88	22.38	23.00	24.00	24.12	7.50		

1. Valves which meet EN flange standards and have DN face-to-face dimensions are available only from Europe. Valves which meet EN flange standards but not DN face-to-face standards are available in the US. Consult your Emerson Process Management sales office.

Figure 7. Fisher ES Dimensions (also see tables 13, 14, and 15)

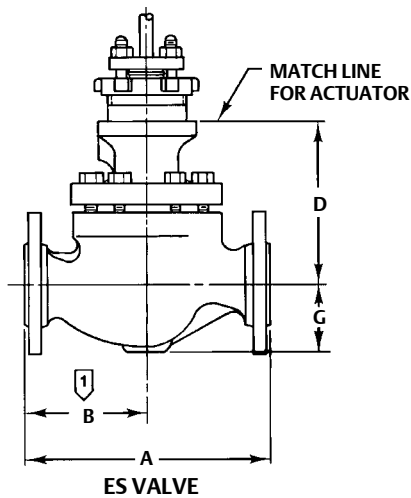

AR4967-A  
10A7397-B  
B1534-1

Note:

1 > B =  $\frac{A}{2}$

Table 14. Fisher ES Dimensions

VALVE SIZE, NPS	D FOR PLAIN BONNET			
	ES			
	Stem Diameter			
	mm			
	9.5	12.7	19.1	25.4 or 31.8
1/2, 3/4, 1, 1-1/4	127	149	---	---
1-1/2	124	146	---	---
2	---	165	162	---
2-1/2	---	187	184	---
3	---	191	187	---
4	---	221	217	264
6	---	---	251	270
8	---	---	375 <sup>(1)</sup>	426
	Inches			
	3/8	1/2	3/4	1 or 1-1/4
1/2, 3/4, 1, 1-1/4	5.00	5.88	---	---
1-1/2	4.88	5.75	---	---
2	---	6.50	6.38	---
2-1/2	---	7.38	7.25	---
3	---	7.50	7.38	---
4	---	8.69	8.56	10.38
6	---	---	9.88	10.62
8	---	---	14.75 <sup>(1)</sup>	16.75

1. Available only in cast iron or WCC steel for the stem diameter with plain bonnet.

Table 15. Fisher ES Dimensions

VALVE SIZE, NPS	D FOR EXTENSION AND ENVIRO-SEAL BELLOWS SEAL BONNETS (ES ONLY)									
	Style 1 Ext. Bonnet				Style 2 Ext. Bonnet			ENVIRO-SEAL Bellows Seal Bonnet		
	Stem Diameter				Stem Diameter			Stem Diameter		
	mm									
	9.5	12.7	19.1	25.4 or 31.8	9.5	12.7	19.1	9.5	12.7	19.1
1/2, 3/4, 1, 1-1/4	213	251	---	---	303	319	---	321	---	---
1-1/2	210	248	---	---	300	316	---	317	---	---
2	---	267	---	---	---	465	---	---	384	---
2-1/2	---	289	272	---	---	492	---	---	---	---
3	---	292	297	---	---	495	487	---	518	518
4	---	322	327	370	---	526	518	---	541	---
6	---	---	357	402	---	---	543	---	---	573
8	---	---	421	450	---	---	621	---	---	---
	Inches									
	3/8	1/2	3/4	1 or 1-1/4	3/8	1/2	3/4	3/8	1/2	3/4
1/2, 3/4, 1, 1-1/4	8.38	9.88	---	---	11.94	12.56	---	12.62	---	---
1-1/2	8.25	9.75	---	---	11.81	12.44	---	12.50	---	---
2	---	10.50	---	---	---	18.31	---	---	15.12	---
2-1/2	---	11.38	10.69	---	---	19.38	---	---	---	---
3	---	11.50	11.69	---	---	19.50	19.19	---	20.38	20.38
4	---	12.69	12.88	14.56	---	20.69	20.38	---	21.31	---
6	---	---	14.06	15.81	---	---	21.38	---	---	22.56
8	---	---	16.56	17.75	---	---	24.44	---	---	---

Table 16. Fisher EAS Dimensions

VALVE SIZE, NPS	AA					
	CL150		CL300		CL600	
	RF	RTJ	RF	RTJ	BW, SW, or RF	RTJ
	mm					
1	92	98	98	105	105	105
2	127	133	133	141	143	144
3	149	156	159	167	168	170
4	176	183	184	197	197	198
6	225	232	237	244	254	256
	Inches					
1	3.62	3.88	3.88	4.12	4.12	4.12
2	5.00	5.25	5.25	5.56	5.62	5.69
3	5.88	6.12	6.25	6.56	6.62	6.69
4	6.94	7.19	7.25	7.56	7.75	7.81
6	8.88	9.12	9.31	9.62	10.00	10.06

Figure 8. Fisher EAS Dimensions (also see tables 16 and 17)

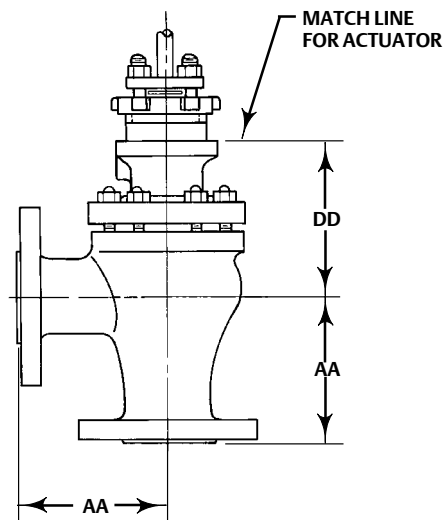

AU6190-A  
A0927-1

Note:  
For dimensions of valves with EN (or other) end connections, consult your Emerson sales office.

Table 17. Fisher EAS Dimensions

VALVE SIZE, NPS	DD												
	Plain Bonnet				Style 1 Extension Bonnet			Style 2 Extension Bonnet			ENVIRO-SEAL Bellows Seal Bonnet		
	Stem Diameter												
	mm												
	9.5	12.7	19.1	25.4 or 31.8	9.5	12.7	19.1	9.5	12.7	19.1	9.5	12.7	19.1
1	111	133	---	---	197	235	---	291	305	---	Contact your nearest Emerson sales office		
2	98	121	---	---	184	223	---	278	291	---			
3	---	149	146	---	---	251	256	---	454	---			
4	---	140	137	---	---	241	246	---	445	437			
6	---	144	141	187	---	246	251	---	449	441			
	Inches												
	3/8	1/2	3/4	1 or 1-1/4	3/8	1/2	3/4	3/8	1/2	3/4	3/8	1/2	3/4
1	4.38	5.25	---	---	7.75	9.25	---	11.44	12.00	---	Contact your nearest Emerson sales office		
2	3.88	4.75	---	---	7.25	8.75	---	10.94	11.44	---			
3	---	5.88	5.75	---	---	9.88	10.06	---	17.88	---			
4	---	5.50	5.38	---	---	9.50	9.69	---	17.50	17.19			
6	---	5.69	5.56	7.38	---	9.69	9.88	---	17.69	17.38			

**Neither Emerson, Emerson Process Management, nor any of their affiliated entities assumes responsibility for the selection, use or maintenance of any product. Responsibility for proper selection, use, and maintenance of any product remains solely with the purchaser and end user.**

Fisher, easy-e, ENVIRO-SEAL, and Whisper Trim are marks owned by one of the companies in the Emerson Process Management business unit of Emerson Electric Co. Emerson Process Management, Emerson, and the Emerson logo are trademarks and service marks of Emerson Electric Co. All other marks are the property of their respective owners.

The contents of this publication are presented for informational purposes only, and while every effort has been made to ensure their accuracy, they are not to be construed as warranties or guarantees, express or implied, regarding the products or services described herein or their use or applicability. All sales are governed by our terms and conditions, which are available upon request. We reserve the right to modify or improve the designs or specifications of such products at any time without notice.

По вопросам продаж и поддержки обращайтесь:

Волгоград (844)278-03-48, Воронеж (473)204-51-73, Екатеринбург (343)384-55-89, Казань(843)206-01-48, Краснодар(861)203-40-90, Красноярск(391)204-63-61,  
Москва(495)268-04-70, Нижний Новгород(831)429-08-12, Самара(846)206-03-16, Санкт-Петербург(812)309-46-40, Саратов(845)249-38-78,  
Единый адрес: [fhv@nt-rt.ru](mailto:fhv@nt-rt.ru)