

Baumann™ 51000 High-Pressure, Low-Flow Control Valve

The Baumann 51000 control valve is optimally designed for demanding low-flow, high-pressure control applications often found in laboratories and pilot plants. NPS 1/4 or 1/2 valve assemblies are standard as either investment cast stainless steel or N10276 nickel alloy. Constructions with other high nickel alloys are available.

With a small footprint, less than 10 inches tall, and multiple trim capacity reductions available to meet changing process requirements, the 51000 is a perfect fit where space is at a premium and flexibility is a must. The valve is suited for demanding control of gases, chemical/dye injection and acid/caustic solutions in paper production, textiles, specialty chemicals, and many other industries.

Features

- Compact Size.
- Suitable for sticky fluids and corrosive atmospheres.
- Quick Trim Change Out - Matched trims not required.
- Investment cast stainless steel body in NPS 1/4 and 1/2, or barstock N10276 Nickel Alloy. Other alloys available.
- Class VI shutoff with soft seat available. Up to 207 barg (3000 psig) at 37°C (100°F).
- Rugged bolted bonnet design.
- Wide flow capacity range. Maximum rated Cv ranges from 0.00013 to 2.5 (0.0002 to 2.16 Kv).
- Corrosion-resistant actuator.
- Available without positioner for fail-open or fail-close applications.



W9733

Baumann 51000 NPS 1/2 Control Valve with TA6000 Electropneumatic Transducer (I/P)



W9734

51000 NPS 1/4 Control Valve with Baumann 16 Actuator, and Fisher® 3660 Pneumatic Positioner



W9066

51000 NPS 1/2 Control Valve with Baumann 16 Actuator, and FIELDVUE™ DVC2000 Digital Valve Controller



Figure 1. NPS 1/4 and 1/2 (6.35 and 12.7 mm) Soft Seat Cage Design for Cv = 0.00013 to 0.45 Class VI Shutoff (N10276 Nickel Alloy Construction Available)

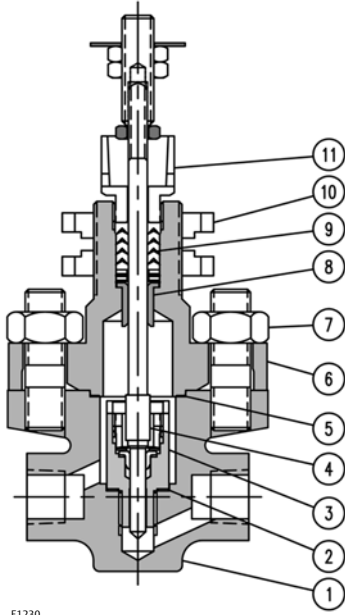

Figure 3. NPS 1/2 (12.7 mm) Integral Seating for Cv = 1.0, 1.5, and 2.5 Class IV Shutoff

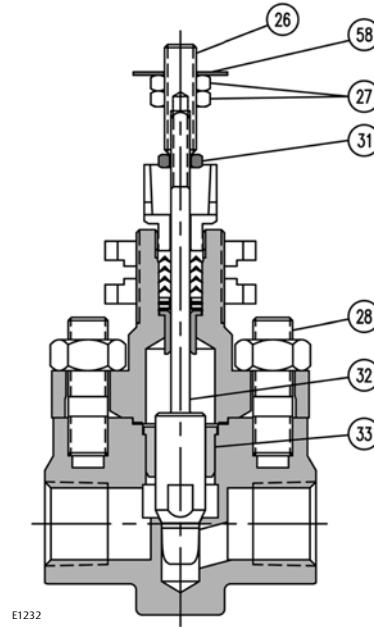
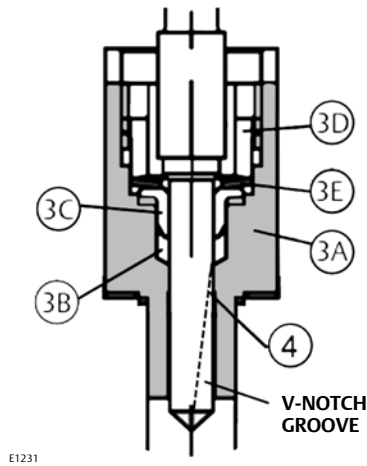

Figure 2. Soft Seat Cage Assembly



The PTFE ring (key 3B) surrounds the valve plug (key 4) to help eliminate clearance flow typical of lapped-in metal-to-metal close clearance micro trims. Flow is directed over the valve plug and forced through a single V-notch path as the plug moves above the PTFE ring, providing precise and predictable control over its entire travel range. When the V-notch moves below the PTFE ring, Class VI primary shutoff is achieved.

A live-loaded metal seat collar (key 3C) fully retains the PTFE ring (key 3B). The valve plug (key 4) seats against the metal collar providing Class IV secondary shutoff. In addition, the fluid process pressure combines with the actuator seating force to form a hydraulic seal within the fully retained PTFE ring (key 3B). Therefore, the higher the process pressure the tighter the shutoff.

Table 1. Baumann 51000 Soft Seat Cage Assembly

Key Number	Parts	Material
3A	Cage	ASTM A276 S31600 Condition A or ASTM B574 N10276, 35 HRC Max
3B	Ring	PTFE (Polytetrafluoroethylene)
3C	Collar	ASTM A276 S31600 Condition A or ASTM B574 N10276, 35 HRC Max
3D		Retainer
3E		Spring

Figure 4. V-Ring Packing Kit

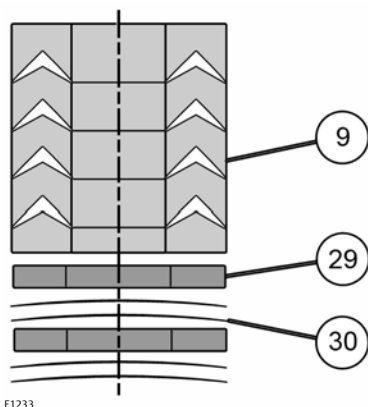

Table 2. Baumann 51000 V-Ring Packing Kit 51607

Key Number	Quantity	Description
9	1	Packing Set
29	2	Flat Washer
3	4	Disc Spring

Table 3. Materials of Construction

Key Number	Parts	Material
1	Valve Body, NPS 1/4 and NPS 1/2	ASTM A351 CF8M or ASTM B575 N10276, 35 HRC Max
2	Seat Cage Gasket	Reinforced Graphite
3	Figure 1 ONLY! Soft Seat Cage Assy, (Cv's 0.00013 to 0.45), (Kv's 0.0002 to 0.39)	See figure 2, table 1
	Seat, Body (Integral Seat) (Cv's 1.0, 1.5, 2.5); (Kv's 0.86, 1.29, 2.16)	ASTM A351 CF8M or ASTM B575 N10276, 35 HRC Max
4	Plug/Stem (Cv's 0.00013 - 0.5); (Kv's 0.0002 to 0.39)	ASTM A479 S21800 Annealed or ASTM B574 N10276, 35 HRC Max
5	Bonnet Gasket	Flexible Graphite and Polymer Composite
6	Bonnet	ASTM A351 CF8M or ASTM B574 N10276, 35 HRC Max
7	Hex Nuts	18-8 Stainless Steel
8	Stem Guide	ASTM A582 S30300 Condition A or Carbon Fiber-Filled Thermoplastic Fluoropolymer
9	V-Ring Packing Kit	PTFE (Polytetrafluoroethylene) & S30400 & S30100
10	Clamp Nut	ASTM A240 S30400
11	Packing Follower Nut	ASTM A582 S30300 Condition A or ASTM B574 N10276, 35 HRC Max
26	Stem Adapter, Baumann 16 Actuator	18-8 Stainless Steel
27	Hex Jam Nut, Baumann 16 Actuator	18-8 Stainless Steel
28	Body Studs	S30400 ASTM A193, B8 Class 1
31	Stem Adapter Nut	18-8 Stainless Steel
32	Plug and Stem S/A (for metal seated plugs) Integral Seat, Cv's 1.0, 1.5, & 2.5; (Kv's 0.86, 1.29, 2.16)	ASTM A276 S31600 Condition A or ASTM B574 N10276, 35 HRC Max
33	Plug Guide	ASTM A479 S21800 Annealed or Carbon Fiber-Filled Thermoplastic Fluoropolymer
34	Flange, Bonnet	ASTM A743 CF8
35	Travel Indicator Disc, Baumann 16 Actuator	18-8 Stainless Steel

Table 4. Flow Coefficients (ASME/ISA/IEC)

Valve Size		Orifice Diameter		Plug Tvl		Trim No.	C _v AT VALVE OPENING - Percent of Plug Travel						
mm	NPS	mm	in.	mm	in.		5	10	20	30	40	50	60
6.35 12.7	1/4 1/2	3.97	0.156	12.7	0.5	16	0.000001	0.000003	0.00001	0.00002	0.00003	0.00005	0.00006
						15	0.000002	0.000006	0.00002	0.00004	0.00006	0.00009	0.00011
						14	0.000004	0.000014	0.00004	0.00006	0.00009	0.00013	0.00021
						13	0.00001	0.00003	0.00008	0.00012	0.00017	0.00025	0.00037
						12	0.00002	0.00007	0.00017	0.00025	0.00036	0.0005	0.0007
						11	0.00004	0.0001	0.00025	0.00040	0.00058	0.0009	0.0014
						10	0.00008	0.00015	0.00030	0.00057	0.0010	0.0017	0.0029
						09	0.00009	0.00018	0.00040	0.0008	0.0016	0.0031	0.0057
						08	0.00010	0.00020	0.0005	0.0012	0.0028	0.006	0.010
						07	0.00012	0.00025	0.0007	0.0019	0.005	0.011	0.022
						06	0.00015	0.0003	0.001	0.003	0.008	0.021	0.040
						05	0.0002	0.0005	0.002	0.006	0.016	0.04	0.079
12.7	1/2	9.53	0.375	12.7	0.5	04	0.0017	0.005	0.011	0.02	0.034	0.06	0.11
						03	0.009	0.014	0.030	0.06	0.11	0.17	0.25
						02	0.015	0.020	0.050	0.10	0.15	0.25	0.37
						01	0.023	0.035	0.075	0.15	0.25	0.42	0.61

Table 5. Flow Coefficients (ASME/ISA/IEC) (continued)

Valve Size		Orifice Diameter		Plug Tvl		Trim No.	C _v AT VALVE OPENING - Percent of Plug Travel				F _d	F _L	X _T	K _C
mm	NPS	mm	in.	mm	in.		70	80	90	100				
6.35 12.7	1/4 1/2	3.97	0.156	12.7	0.5	16	0.00008	0.0001	0.0012	0.00013	0.035	0.98	0.80	0.94
						15	0.00015	0.0002	0.00023	0.00025	0.04			
						14	0.00031	0.0004	0.00045	0.0005	0.05			
						13	0.0006	0.0008	0.0009	0.001	0.06			
						12	0.0010	0.0015	0.0018	0.002	0.075			
						11	0.0020	0.0029	0.0036	0.004	0.10			
						10	0.0046	0.0062	0.0072	0.008	0.11			
						09	0.0087	0.011	0.014	0.015	0.15			
						08	0.016	0.022	0.026	0.03	0.18			
						07	0.035	0.046	0.054	0.06	0.22			
						06	0.062	0.08	0.09	0.10	0.25			
						05	0.12	0.16	0.18	0.20	0.3			
12.7	1/2	9.53	0.375	12.7	0.5	04	0.19	0.29	0.38	0.45	0.4			
						03	0.35	0.45	0.60	1.0	0.23	0.95	0.75	0.86
						02	0.50	0.72	1.2	1.5	0.31	0.90	0.68	0.73
						01	0.88	1.2	1.7	2.5	0.60	0.88	0.65	0.68

Table 6. Valve Body S/A Pressure-Temperature Ratings

WORKING PRESSURE (barg)			WORKING PRESSURE (psig)		
Temperature (°C)	ASTM A351 CF8M	ASTM B575 N10276, 35 HRC Max	Temperature (°F)	ASTM A351 CF8M	ASTM B575 N10276, 35 HRC Max
-195 to 37.8	207	207	-320 to 100	3000	3000
93.3	178	207	200	2580	3000
149	161	207	300	2330	3000
176	154	207	350	2235	3000

51000 Valve

Baumann 16 Actuator

The Baumann 16 actuator is single acting, pneumatic with spring-return action. It is a compact, multi-spring actuator with low operating friction. It can be reversed in the field (air-to-open or air-to-close) without special tools or additional parts.

Multiple springs determine the bench set; there is no need for a bench set adjustment.

It can be mounted with the TA6000 transducer, Fisher 3660 pneumatic or 3661 electropneumatic valve positioners, or FIELDVUE digital valve controllers.

Figure 5. Baumann 16 Actuator Sectional

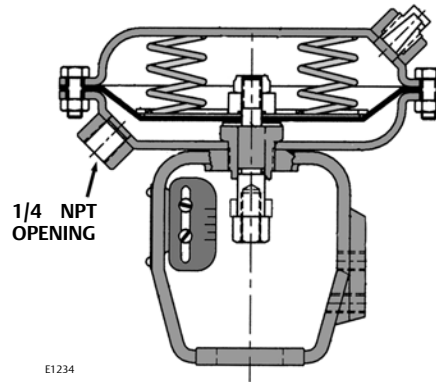

Table 7. Actuator Construction

Actuator Type	Parts	Material
16	Diaphragm	CR (Chloroprene), TPES (Polyester Thermoplastic)
	Diaphragm Plate	S30200 or S30400
	Diaphragm Casing	Carbon Steel (AISI G10080/G10090/G10100)
	Yoke	ASTM A743 CF8
	Stem	ASTM A582 S30300 Condition A

Table 8. Actuator Specifications

Type	16 Multi-Spring Diaphragm (Single Acting)
Nominal Size	103 cm ² (16 in ²)
Air Failure	Open or Closed (Field Reversible)
Bench Spring Range	0.2 - 0.8 bar (3-12 psi), fail-open / 0.3 - 0.9 bar (4-13 psi), fail-closed
Travel	12.7 mm (0.5 inch)
Ambient Temperature Range	-29 to 71°C (-20 to 160°F)
Maximum Air Pressure	2.41 barg (35 psig)
Diaphragm Material	CR (Chloroprene), TPES (Polyester Thermoplastic)
Spring Cases	Steel, Powder Epoxy-Coated Appliance White per FDA 21 CFR 175.300 with Stainless Steel Fasteners
Yoke	CF8M Stainless Steel
Weight	2.1 kg (4.6 lbs)

Table 9. 51000 Series Valve with Baumann 16 Actuator and Positioner (Metric)

PERFORMANCE SPECIFICATIONS				ALLOWABLE PRESSURE DROPS			
Valve Size, mm	K _V Range	Process Temperature Range	Seat Leakage (per ASME/ FCI 70-2)	Bench Spring Range	Air-to-Open ⁽¹⁾	Bench Spring Range	Air-to-Close ⁽¹⁾
6.35 & 12.7	0.0002 - 0.39	-28.9 to 177°C	Class VI	0.3 - 0.9 bar	207 bar	0.2 - 0.8 bar	207 bar
12.7	0.86, 1.29, 2.16	-28.9 to 232°C	Class IV	0.3 - 0.9 bar	28 bar	0.2 - 0.8 bar	55 bar

1. Based on 1.4 barg air supply to positioner.

Table 10. 51000 Series Valve with Baumann 16 Actuator and Positioner

PERFORMANCE SPECIFICATIONS				ALLOWABLE PRESSURE DROPS			
Valve Size, NPS	C _V Range	Process Temperature Range	Seat Leakage (per ASME/ FCI 70-2)	Bench Spring Range	Air-to-Open ⁽¹⁾	Bench Spring Range	Air-to-Close ⁽¹⁾
1/4 & 1/2	0.00013 - 0.45	-20 to 350°F	Class VI	4-13 psi	3000 psi	3-12 psi	3000 psi
1/2	1.0, 1.5, 2.5	-20 to 450°F	Class IV	4-13 psi	400 psi	3-12 psi	800 psi

1. Based on 20 psig air supply to positioner.

Table 11. 51000 Series Valve with Baumann 16 Actuator without Positioner or with Transducer (Metric)

PERFORMANCE SPECIFICATIONS				ALLOWABLE PRESSURE DROPS			
Valve Size, mm	K _V Range	Process Temperature Range	Seat Leakage (per ASME/ FCI 70-2)	Bench Spring Range	Air-to-Open ⁽¹⁾	Bench Spring Range	Air-to-Close ⁽¹⁾
6.35 & 12.7	0.0002 - 0.39	-28.9 to 177°C	Class VI	0.3 - 0.9 bar	69 bar	0.2 - 0.8 bar	207 bar
12.7	0.86, 1.29, 2.16	-28.9 to 232°C	Class IV	0.3 - 0.9 bar	6.8 bar	0.2 - 0.8 bar	20.6 bar

1. Based on 0.2 to 1.0 bar air output signal to actuator.

Table 12. 51000 Series Valve with Baumann 16 Actuator without Positioner or with Transducer

PERFORMANCE SPECIFICATIONS				ALLOWABLE PRESSURE DROPS			
Valve Size, NPS	C _V Range	Process Temperature Range	Seat Leakage (per ASME/ FCI 70-2)	Bench Spring Range	Air-to-Open ⁽¹⁾	Bench Spring Range	Air-to-Close ⁽¹⁾
1/4 & 1/2	0.00013 - 0.45	-20 to 350°F	Class VI	4-13 psi	1000 psi	3-12 psi	3000 psi
1/2	1.0, 1.5, 2.5	-20 to 450°F	Class IV	4-13 psi	100 psi	3-12 psi	300 psi

1. Based on 3 to 15 psi air output signal to actuator.

51000 Valve

Table 13. TA6000 Transducer Functional Specifications

		BAR	PSI	kPa
OUTPUT RANGE		0.2-1.0	3-15	20-100
SUPPLY PRESSURE ⁽¹⁾		1.5-8.0	20-120	150-800
MINIMUM SPAN		0.4	5	35
SUPPLY PRESSURE EFFECT ON OUTPUT	Output Change	0.02	0.25	1.7
	Supply Change	1.7	25	170
INPUT SIGNAL, 4-20 mA		Impedance (OHMS), 197		
ENCLOSURE RATING		NEMA 2		
AIR CONSUMPTION (per ISA 551.1) SCFH		5.0 / (0.14m ³ /HR)		
FLOW RATE (SCFM)		2.5 (4.25m ³ /HR) @ 1.7 bar (25 psig) / 170 kPa Supply & 0.6 bar (9 psig) / 60 kPa Output		
TEMPERATURE RANGE (per ISA 551.1)		-28.9 to 65°C (-20 to 150°F)		
1. Supply pressure must be no less than 0.4 bar (5 psi), (35 kPa) above maximum output.				

Table 14. TA6000 Transducer Performance Specifications

		PSI	BAR	kPa
OUTPUT RANGE		3-15	0.2-1.0	20-100
INDEPENDENT LINEARITY (per ISA 551.1)		+/-0.5% Full Span		
HYSTERESIS & REPEATABILITY (per ISA 551.1)		0.25% Full Span		
RFI/EMI EFFECT		Less than 0.5% of Span @ 30 v/m Class 3 Band ABC (20-1000 mHz) per SAMA PMC 33.1 1978 and Less than 0.5% of Span @ 10 v/m Level 3, 27-500 mHz Band per IEC Standard 801-3 1984. EMC Directive 89/336/EEC European Norms EN50081-2 and EN50082-2.		

Table 15. TA6000 Transducer Materials of Construction

Parts	Material
Valve body and housing	Aluminum
Orifice	Nickel Plated Brass
Trim	Zinc Plated Steel
Diaphragm	NBR (Nitrile)

Baumann 16 Actuator with TA6000 Transducer Specifications

See figures 6, 7, and 8.

Figure 6. Baumann 16 Actuator (Front View)

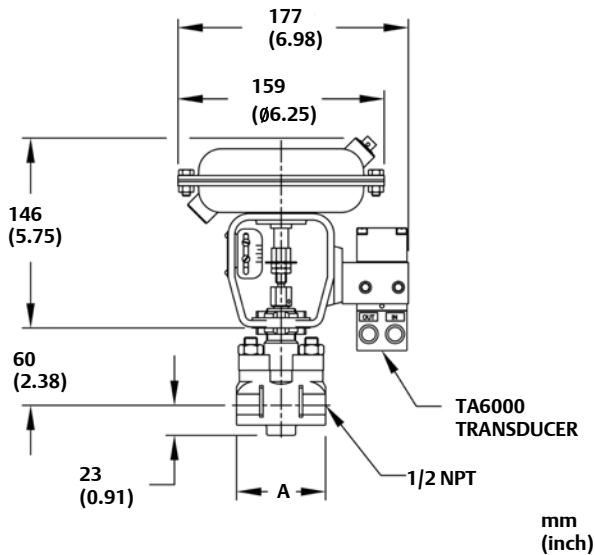

E1235

Figure 7. Baumann 16 Actuator with TA6000 (Top View)

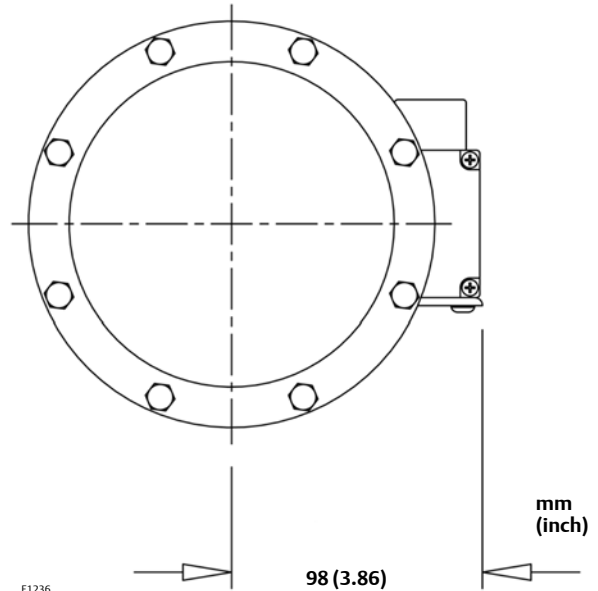

E1236

Figure 8. TA6000 Electropneumatic Transducer Dimensions

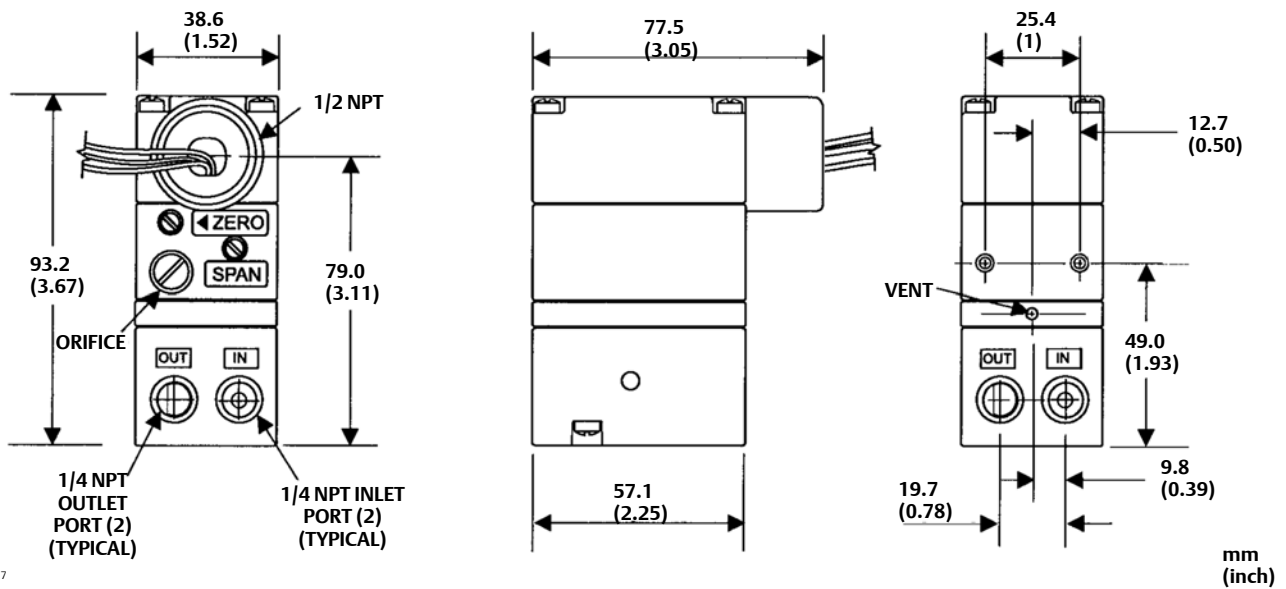

E1237

51000 Valve

Figure 9. Dimensional Drawings

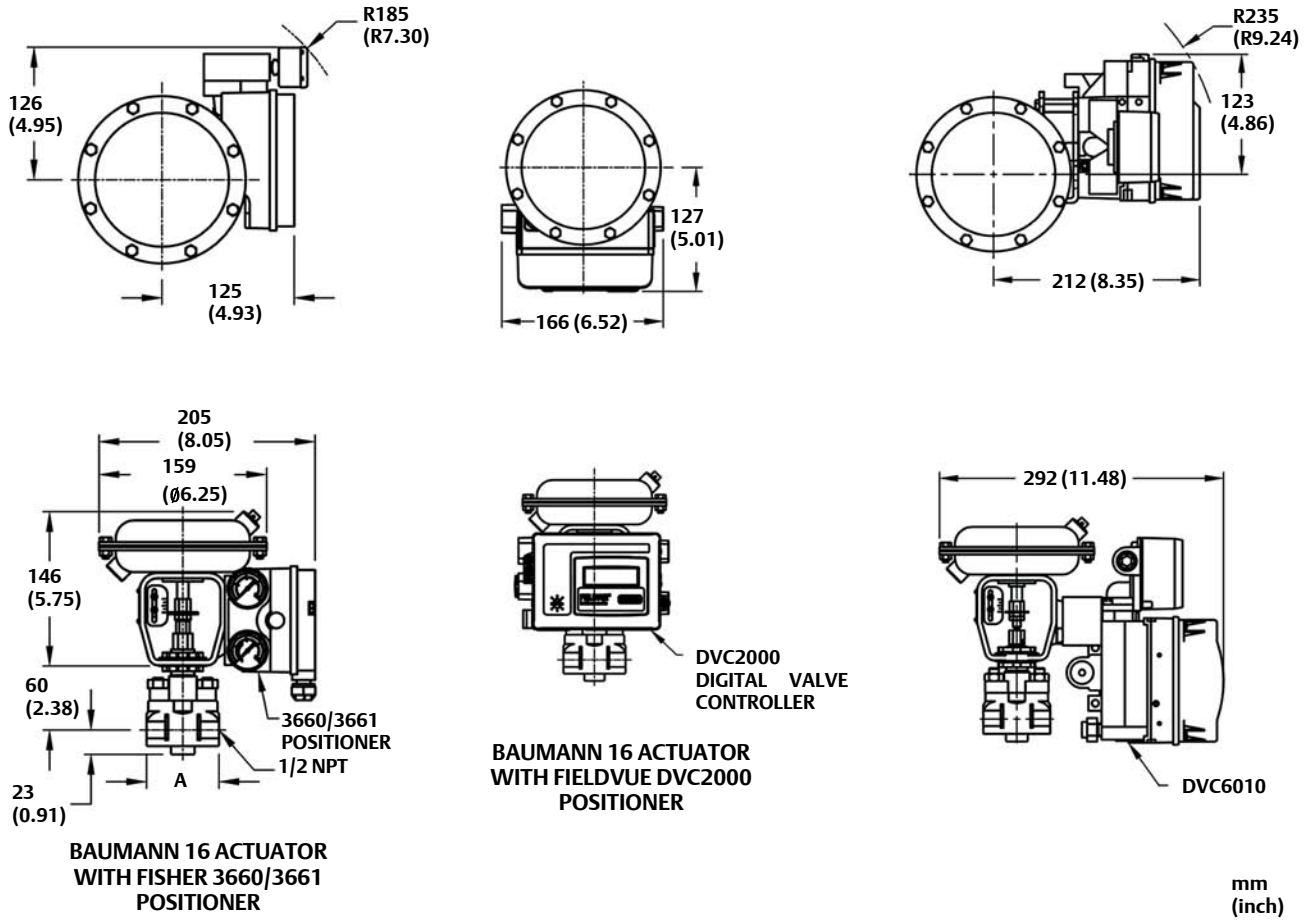

E1238

Table 16. Dimensions and Weights, Valve Body Subassembly

VALVE SIZE		A		MATERIAL	APPROXIMATE WEIGHTS	
mm	NPS	mm	inch		kgs	lbs
6.35	1/4	55.9	2.20	Stainless Steel	0.64	1.4
				N10276 Nickel Alloy	1.0	2.2
12.7	1/2	68.6	2.70	Stainless Steel	0.82	1.8
				N10276 Nickel Alloy	1.18	2.6

Table 17. Weights, Actuator and Instruments Only

ACTUATOR TYPE	INSTRUMENT	APPROXIMATE WEIGHT	
		kg	lbs
16	Actuator without instrument	2.1	4.6
	Fisher 3660/3661 Positioner	3.6	8.0
	FIELDVUE DVC2000	3.8	8.3
	FIELDVUE DVC6010 (Aluminum)	5.8	12.7
	FIELDVUE DVC6010 (SST)	10.0	22.0
	FIELDVUE DVC6010f	5.0	11.0
	TA6000 Electropneumatic Transducer	2.5	5.5

Table 18. Rated Cv Comparison Chart

VALVE SIZE NPS	51000 TRIM NUMBER	51000 RATED Cv	COMPETITIVE RATED Cv	COMPETITIVE TRIM DESIGNATION
1/2 only	01	2.5	2.5 / 2.0	A & B
	02	1.5	1.25	C
	03	1.0	0.80	D
1/4 1/2	04	0.45	0.50 / 0.32	E & F
	05	0.20	0.20 / 0.13	G & H
	06	0.10	0.08	I
	07	0.06	0.05	J
	08	0.03	0.03 / 0.02	K & L
	09	0.015	0.01	M
	10	0.008	0.006	N
	11	0.004	0.003	O
	12	0.002	0.002 / 0.0013	P1 & P2
	13	0.001	0.001 / 0.0006	P3 & P4
	14	0.0005	0.0004 / 0.00027	P5 & P6
	15	0.00025	0.00018	P7
	16	0.00013	0.00012 - 0.00001	P8 - P14 ⁽¹⁾

1. P10-P14 trims in NPS 1/4 only.

51000 Valve

Table 19. Model Numbering System

16 Actuator Size	51 51000	Valve Size			Trim No.	Cv	Kv	Instrument		Valve Body Material		Fail Option	
			mm	NPS									
16		1	6.35	1/4	01	2.5 ⁽¹⁾	2.16 ⁽¹⁾	0 ⁽²⁾	None	S	CF8M	O	Open
		2	12.7	1/2	02	1.5 ⁽¹⁾	1.29 ⁽¹⁾	1 ⁽³⁾	Pneumatic (3-15 psi)	C	N10276	C	Closed
					03	1.0 ⁽¹⁾	0.86 ⁽¹⁾	2 ⁽⁴⁾	I/P Positioner (4-20 mA)				
					04	0.45	0.39	3 ⁽⁵⁾	I/X Transducer (4-20 mA)				
					05	0.20	0.17						
					06	0.10	0.09						
					07	0.060	0.05						
					08	0.030	0.026						
					09	0.015	0.013						
					10	0.008	0.0069						
					11	0.004	0.0035						
					12	0.002	0.0018						
					13	0.001	0.0009						
					14	0.0005	0.0005						
					15	0.00025	0.0003						
					16	0.00013	0.0002						

1. Available in NPS 1/2 valve only.
 2. Baumann 16 actuator.
 3. 16 with 3660.
 4. 16 with 3661.
 5. 16 with TA6000.

Neither Emerson, Emerson Process Management, nor any of their affiliated entities assumes responsibility for the selection, use or maintenance of any product. Responsibility for proper selection, use, and maintenance of any product remains solely with the purchaser and end user.

Baumann, Fisher, and FIELDVUE are marks owned by one of the companies in the Emerson Process Management business unit of Emerson Electric Co. Emerson Process Management, Emerson, and the Emerson logo are trademarks and service marks of Emerson Electric Co. All other marks are the property of their respective owners.

The contents of this publication are presented for informational purposes only, and while every effort has been made to ensure their accuracy, they are not to be construed as warranties or guarantees, express or implied, regarding the products or services described herein or their use or applicability. All sales are governed by our terms and conditions, which are available upon request. We reserve the right to modify or improve the designs or specifications of such products at any time without notice.

По вопросам продаж и поддержки обращайтесь:

Волгоград (844)278-03-48, Воронеж (473)204-51-73, Екатеринбург (343)384-55-89, Казань(843)206-01-48, Краснодар(861)203-40-90, Красноярск(391)204-63-61,
Москва(495)268-04-70, Нижний Новгород(831)429-08-12, Самара(846)206-03-16, Санкт-Петербург(812)309-46-40, Саратов(845)249-38-78,
Единый адрес: fhv@nt-rt.ru